



Drying of

parts

of any kind

VAT

## Roundtub Driers VAT



**SPALECK**  
Oberflächentechnik

80

60

90

120

150

180

## Roundtub Driers VAT 11, VAT 33, VAT 55

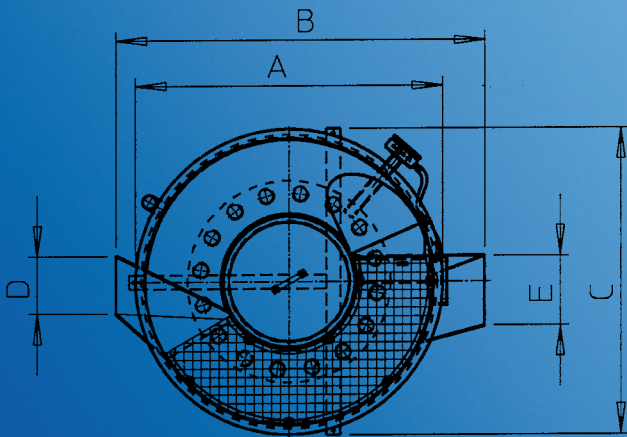
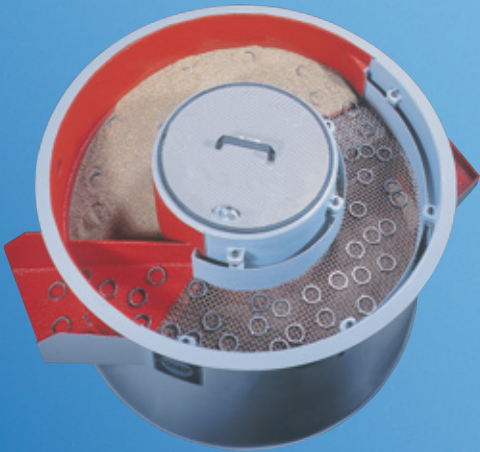

- ▲ For a residue-free drying of parts after surface treatment
- ▲ The extremely long zone of separation guarantees that the parts are leaving the drier without any granulate
- ▲ The continuous ascent of the working tub assures a good rotation of the mass and thus an optimal transport and discharge of the parts
- ▲ Due to the fact that inlet and discharge are positioned opposite, this drier may be integrated linear in a complete line

Technical data:	VAT 11	VAT 33	VAT 55
Volume of the tub in l	120	230	550
Operating voltage	400V / 50 Hz	400V / 50 Hz	400V / 50 Hz
Motor output in kW	1,3	1,6	2,9
Motor speed rpm	1460	1500	1460
Max. heating capacity in kW	4,8 / 9,6	3,6 / 7,2	6 / 12
Empty weight in kg (basic machine)	500	700	1350
Max. operation weight in kg	750	1200	2600
Space requirements in m <sup>2</sup>	1,7	2,4	3,7

Dimensions in mm:	VAT 11	VAT 33	VAT 55
A	1125	1350	1755
B	1440	1655	2110
C	830	1425	1760
D	280	325	330
E	280	400	400
F	850	910	1225
G	780	850	1170
H	540	565	845
J	460	450	715

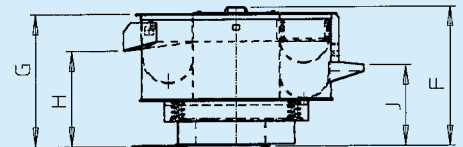

Subject to technical modifications

# VAT



SPALECK Oberflächentechnik GmbH + Co. KG  
 Postfach 2253 · D-46372 Bocholt  
 Schlävenhorst 117 · D-46395 Bocholt  
 Telefon +49 (0) 28 71 / 95 00-0  
 Telefax +49 (0) 28 71 / 95 00-95  
 www.spaleck.biz · info@spaleck.biz

