



Deburring

Radiusing

Polishing

Burnishing

Ball burnishing

Barrel Finishers RTS



SPALECK
Oberflächentechnik

30

60

90

120

150

180

Barrel Finishers RTS



- ▲ Separating device with media collection hopper integrated into the machine base for easy operation in a dry atmosphere
- ▲ Barrels of different sizes can be used on the same machine stand
- ▲ The use of two barrels allows simultaneous treatment of different parts
- ▲ Low space requirement, completely assembled ready for connection
- ▲ Barrel with highly wear-resistant polyurethane lining
- ▲ A protection cap assures safe working conditions



Barrels:

Technical data / Dimensions:	RTS 1	RTS 2	RTS 3	RTS 4
Possible no. of barrels	2	2	1	1
Barrel capacity in l	9	15	35	50
Usable volume in l	6	9	25	40
Max. filling weight in kg per barrel	30	45	120	180
Barrel speed rpm	62	44	44	38
Barrel dimensions in mm	Ø 330x260	Ø 460x260	Ø 460x530	Ø 530x530

Basic machine:

Technical data:	RTS	Dimensions in mm	RTS
Drive in kW	0,75	A	1980
Operating voltage	400 V / 50 Hz	B	1375
Empty weight in kg	150	C	820
Space requirement in m ²	1,2	D	1455
		E	720
		F	640
		G	970

Subject to technical modifications

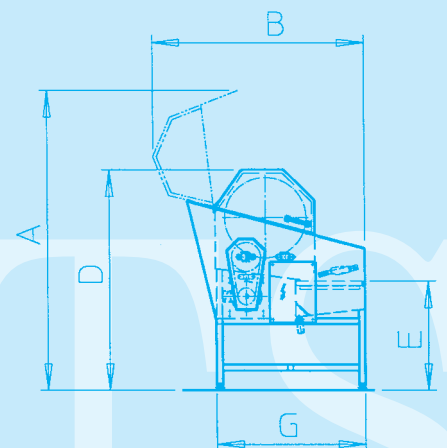

SPALECK Oberflächentechnik GmbH + Co. KG
 Postfach 2253 · D-46372 Bocholt
 Schlavenhorst 117 · D-46395 Bocholt
 Telefon +49 (0) 28 71 / 95 00-0
 Telefax +49 (0) 28 71 / 95 00-95
 www.spaleck.biz · info@spaleck.biz